

# MiTi<sup>®</sup> Developments

Mohawk Innovative  
Technology, Inc.



Vol. 25

November 2005

## OIL-FREE, MOTORIZED, AUTOMOTIVE FUEL CELL AIR COMPRESSOR/EXPANDER SYSTEM

Under a jointly funded NYSERDA<sup>†</sup> and MiTi<sup>®</sup> project, an oil-free, fuel cell air compressor has been designed, built and tested and is now available for custom fitting to individual automotive designs. This development has addressed the unique needs for oil-free air, simplicity, compactness, high-reliability, very low maintenance and acquisition costs, in a high turndown ratio system that meets airflow demands from idle conditions to maximum power and eliminates acceleration lag.

MiTi<sup>®</sup> has combined its world-leading expertise in compliant foil gas bearing design with years of turbocharger and oil-free compressor development activities to configure a novel compressor/expander system operating cycle that uses a single, motorized, foil bearing mounted spindle. A unique fuel cell exhaust energy recovery cycle was designed to address the needs of this demanding application. This system provides the means to alleviate the acceleration lag tendencies of more conventional approaches and to achieve the ultra-low flow rates to the fuel cell required during idle and low power conditions.

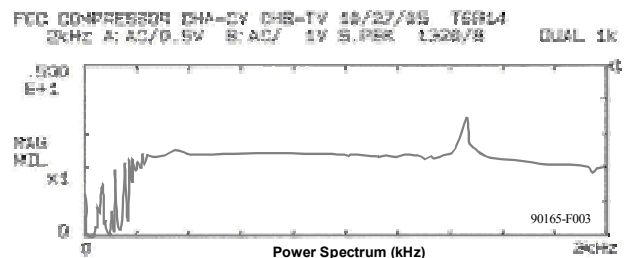
The MiTi<sup>®</sup> Fuel Cell Compressor/Expander shown in Figure 1 illustrates the simplicity of our single spindle design. Compactly contained in a single housing, with no couplings or lube system requirements, the motorized compressor incorporates several MiTi<sup>®</sup> developed enabling technologies to achieve unparalleled performance, combined with the life and reliability requirements of the automotive industry.

The MiTi<sup>®</sup> system incorporates a 12 kW, Permanent Magnet motor, powered by a high quality signal (Sieb & Meyer) controller. This “clean signal” power source enables maximum conversion of electrical power by the motor, improving motor efficiency while reducing heat dissipation loads. A water-cooled jacket maintains proper stator temperature. The unit can operate from 20,000 to 120,000 rpm to meet pressure and flow demands. This speed range results in operation well above the rotor first bending critical speed, as shown in Figure 2. The system can operate in a horizontal, vertical or intermediate rotor orientation, depending upon installation needs. The outstanding load carrying and damping capacities of the MiTi<sup>®</sup> foil bearing make this high-speed operation possible and assures smooth, stable operation throughout the entire operating range. No comparable system is available from any other source.

Figure 3 is a 3-D cutaway drawing of the unit, illustrating individual component arrangement within the assembled unit. Controller and power source selection for the motor are determined according to the application requirements. These can be provided by MiTi<sup>®</sup> or others.

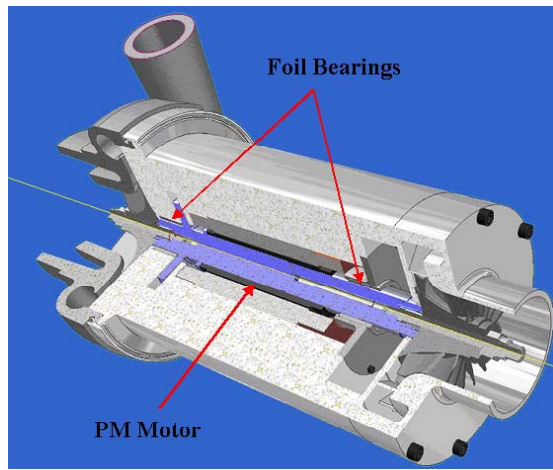


**Figure 1. MiTi<sup>®</sup> Fuel Cell Compressor/Expander System including variable frequency sinusoidal drive**



**Figure 2. Peak hold power spectrum plot showing operation to 120,000 rpm**

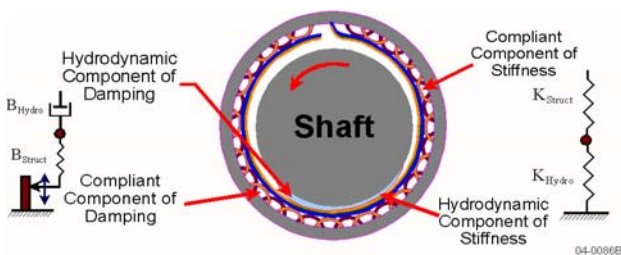
Additional motor driven spindle designs are currently available for custom development and application by MiTi<sup>®</sup>, including 32, 35 and 80 kW, 60,000 rpm synchronous and asynchronous units. Turbocharger qualification tests for mobile operation by automotive industry manufacturers and their customers have been unqualified successes. MiTi<sup>®</sup> motorized spindles can mount compressor impellers or a compressor/expander mix, one on each end. Individual systems can be optimized to meet the needs of specific applications.



**Figure 3. Solid model of motorized compressor/expander**

Several classes of MiTi<sup>®</sup> foil bearings using our KOROLON<sup>™</sup> coatings are available to meet varying duty cycles according to speeds, impeller sizes, thrust loads, etc. Successful tests of MiTi<sup>®</sup> foil bearings, protected by our proprietary KOROLON<sup>™</sup> bearing surface coatings, have been conducted by government agencies and commercial machinery manufacturers to temperatures of 815°C and in saturated ammonia gas demonstrating the durability and life of MiTi<sup>®</sup>'s bearing and coating systems. KOROLON<sup>™</sup> coatings are resistant to alkalis and solvents and have extremely durable surfaces that also have self-healing properties for minor foreign debris induced penetrations. The outstanding wear characteristics of KOROLON<sup>™</sup> coatings also provide long, maintenance-free operational life. The low friction coefficient supports rapid acceleration to rotor levitation speeds (lift-off), enabling use of minimal power source size to meet starting torque requirements.

Supported by a bearing cartridge, the compliant element has a corrugated shape that enables the designer to incorporate a desired mechanical stiffness value through metal gauge selection. The number and span of each corrugation can be designed to meet damping needs. The flexing of each corrugation, when under dynamic loading, causes minute sliding of the contact points along the cartridge surface. The combined static and dynamic friction values of all corrugation contact points provide the major portion of the mechanical damping action. These are supplemented by the dynamic properties of the air film.



**Figure 4. Schematic diagram of foil bearing**

The smooth top foil rides on top of the corrugations and provides the surface needed for the generation of a hydrodynamic air wedge to levitate the rotor. Levitation by

the air film wedge eliminates wear-inducing contact with the bearing while in operation. Viscous losses are a fraction of that of oil film bearings, providing a significant operating efficiency advantage.

The persistent development work pioneered by MiTi<sup>®</sup> engineers has created the technology needed to respond to the urgent needs of government advanced technology programs for over 20 years. These resulting powerful, validity proven, proprietary analytical procedures are now being applied in conjunction with highly developed, computer controlled simulation test routines to optimize the design of commercial quality, foil bearing supported rotor-bearing systems for industrial applications.

Thermal management of the bearing systems cooling requirements is effectively integrated with the air cooling for the integral drive electric motor rotor mounted between the bearings.

The use of highly developed, computerized simulators located in modern, enclosed test cells enables the optimization of specific design features of commercial grade foil bearings, providing outstanding performance and reliability.

### **Key Features of MiTi<sup>®</sup> Foil Bearings**

Extraordinary Load Carrying Capacity

No Speed Limitation

Operates at Temperatures to 815°C (1500°F)

Exceptional Life with KOROLON<sup>™</sup>

-Low friction enhances rapid lift-off

-Wear resistance greatly extends bearing life

-Self-healing mitigates foreign object debris infusion

Drastic Reduction in Power Losses/Heat Generation

-Low viscosity of gas reduces drag

Unlimited Bearing Size Scalability Demonstrated

Completely Self-Acting Hydrodynamic Action

-Requires no external pressurization

Capable of Providing Aircraft Quality Tip Clearances

-Increased compressor/turbine efficiencies

Unparalleled Price to Performance Ratio

-Huge savings shown by life cycle evaluations

High Shock & Vibration Survivability

-Vehicular & mobile system maneuver tolerance

Operation Orientation

-Can operate in any orientation, including vertical

MiTi<sup>®</sup> stands ready to work with you or your vendors to license the technology or design a new product using our foil bearings or to integrate this unit with your existing design and operating requirements.

For additional information, contact:  
 Mohawk Innovative Technology, Inc.  
 1037 Watervliet-Shaker Road  
 Albany, New York 12205  
 Telephone: (518) 862-4290; FAX: (518)862-4291  
 E-mail: [Marketing@miti.cc](mailto:Marketing@miti.cc) Website: <http://www.miti.cc>

† New York State Energy Research Development Authority under the program direction of Mr. Frank Ralbovsky.